

**NOTES:**  
 5,000 PSI CONCRETE  
 6X6 WIRE MESH AND NO. 3 REBAR REINFORCEMENT  
 QTY. 4 SEALS - TUF-TITE TS-4-RUBBER  
 EACH END & 2 ADDITIONAL SIDE INLETS  
 ADDITIONAL TANK CONFIGURATIONS AVAILABLE UPON REQUEST  
 OUTLET PLUMBING DONE BY CONTRACTOR

**TANK WEIGHTS:**  
 TOP WEIGHT = 4,000#  
 BOTTOM WEIGHT = 3,500#  
 TOTAL WEIGHT = 7,500#

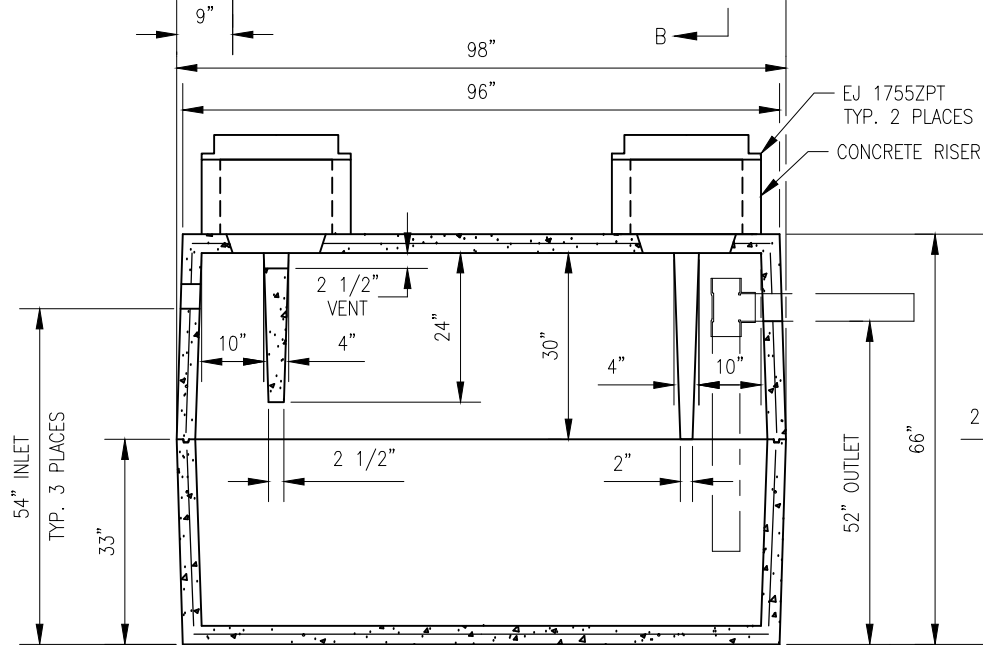

SECTION A-A

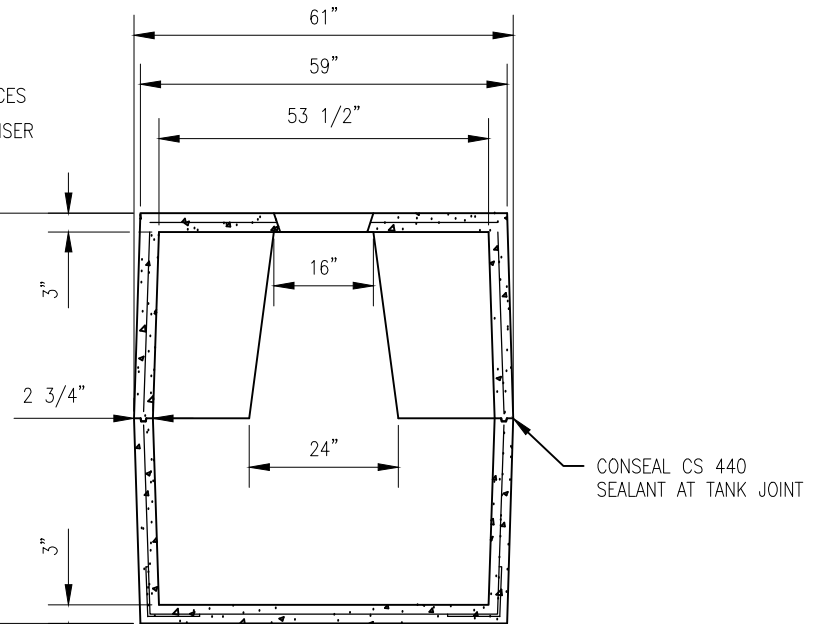

SECTION B-B



QUAKER CITY CONCRETE PRODUCTS  
 290 EAST HIGH STREET  
 LEETONIA, OHIO 44431  
 PHONE: 330-427-2239  
 EMAIL: ESTIMATING@QUAKERCITYCONCRETE.COM

TITLE:

1000 GALLON  
GREASE TRAP

SCALE: NONE	DRAWN: TAR	DATE: 02/27/26	REV. NO.: 1
----------------	---------------	-------------------	----------------